

T 2181 EN

Typetested safety devices

Series 43 Self-operated Temperature Regulators



Application

Control, limitation, safety monitoring and safety limitation of the energy supplied to heat generators or heat exchangers which must be equipped with typetested devices.

Note

Devices tested according to DIN EN 14597 are available for installations according to DIN 4747-1, DIN EN 12828 and DIN 4753.

The safety devices are used to control and protect indirectly heated heat generators in heating and service water heating installations. The temperature regulators, temperature limiters, safety temperature monitors and safety temperature limiters are compulsory according to the relevant regulations (e.g. DIN 4747-1, DIN EN 12828 and DIN 4753) for installations with heat generators or heat exchangers which are heated by steam, hot fluids or by district heating systems. These devices must be tested for reliability and certified accordingly. Therefore, the devices listed in this Information Sheet have been tested by TÜV (German technical surveillance association) and approved with a register number.

Device designations

The designation of safety devices is stipulated in DIN EN 14597 (temperature control devices and temperature limiters for heat generating systems). The temperatures specified in Fig. 1 to Fig. 3 are intended only as a guide to the typical fields of application of the devices shown. The devices needed in each case must meet the requirements of the installation and comply with the relevant safety regulations.

Temperature regulators (TR), which are tested according to DIN EN 14597, are necessary in many installations. They constantly measure the temperature as a controlled variable, compare it with a given set point, correct the actual temperature according to the set point and interrupt the energy supply when the temperature exceeds the set point.

Safety temperature monitors (STM) interrupt the energy supply when the temperature reaches the adjusted limit, when the capillary tube ruptures or when there is a leak in the sensor (Fig. 3). They reset themselves automatically when the temperature has fallen below the limit and the fault has been remedied.

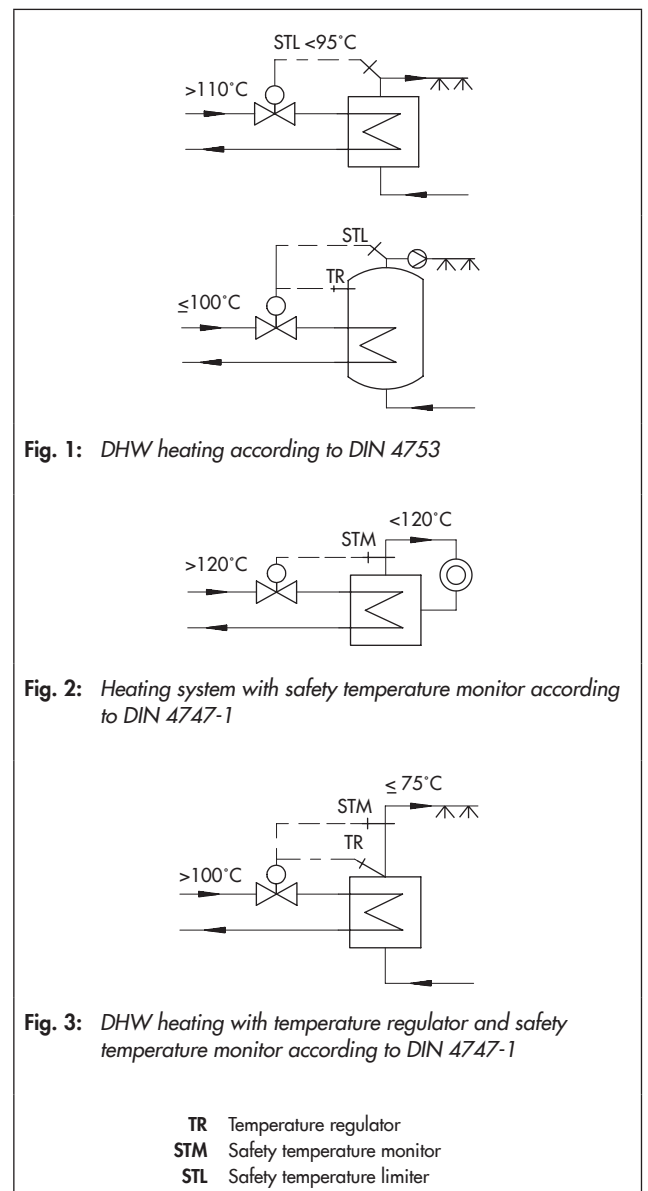

Safety temperature limiters (STL) interrupt and block the energy supply when the temperature reaches the adjusted limit, when the capillary tube ruptures or when there is a leak in the sensor (Fig. 1). They can only be reset and put back into operation with a tool when the temperature has fallen below the limit and the fault has been remedied.

Safety temperature monitors (STM) and safety temperature limiters (STL) are designed for extended safety according to DIN EN 14597 since they are also effective even when a device fails. The safety temperature limiter can be delivered with an electric signal transmitter which produces a signal for fault indication.

Dynamic behavior of control thermostats

The dynamics of the regulator are mainly determined by the response of the sensor with its characteristic time constant.

Table 1 lists the response times of SAMSON control thermostats for Series 43 Regulators operating according to different principles measured in water.

Tested safety equipment

Versions for G ½ to G 1 · DN 15 to 50 · PN 16 or PN 25 Limits up to 120 °C

The temperature sensors of the regulators and limiters function according to the vapor pressure principle or the adsorption principle.

The temperature-dependent pressure change in the sensor causes the valve plug position to change, thus changing the flow rate of the heating medium.

Table 2 shows an overview of Series 43 Regulators.

Regulators tested according to DIN EN 14597

The following versions are available:

- Temperature regulator (TR) with Type 2430 Control Thermostat
- Type 2403 Safety Temperature Monitor (STM)
- Type 2439 Safety Temperature Limiter (STL)

The register number is available on request.

For more details refer to Data Sheet ► T 2185.

Table 1: Dynamic behavior of control thermostats (in seconds)

Principle	Type	Thermowell			
		Without		With	
Adsorption	2430	15 s ¹⁾	30 s ²⁾	40 s ¹⁾	80 s ²⁾
	2439	– ³⁾		40 s	
Vapor pressure	2403	3 s		– ³⁾	

¹⁾ DN 15 to 25 ²⁾ DN 32 to 50 ³⁾ Not permissible

Table 2: Overview of Series 43 Temperature Regulators

Type ... Regulator	Type	With valve		Pressure rating	Refer to Data Sheet ...
		Connection size			
43-1	2431	G ½ to G 1 ¹⁾³⁾		PN 25	► T 2171
43-2	2432	DN 15 to 50 ¹⁾²⁾			
		DN 15 · 25 ⁴⁾			
43-3	2433 ¹⁾	G ½ to G 1			► T 2173
		DN 15 to 50			
43-5	2435 ¹⁾	G ½ to G 1			► T 2172
43-6	2436	G ½ to G 1 ¹⁾³⁾			
		DN 32 to 50 ¹⁾			
		DN 15 to 50 ²⁾			
43-7	2437	DN 15 to 50 ¹⁾²⁾		► T 2178	
		DN 15 ¹⁾			
Double adapter/manual adjuster/intermediate insulating piece					► T 2176

- ¹⁾ Material CC499K
²⁾ Flanged valve body of EN-GJS-400-18-LT
³⁾ Material 1.4408
⁴⁾ Flanged valve body of 1.4408

Legend for Fig. 4 to Fig. 8

- 1 Type 2431, Type 2435 and Type 2436 Globe Valve with female thread
- 2 Type 2432, Type 2436 and Type 2437 Globe Valve with male thread
- 3 Type 2432, Type 2436 and Type 2437 Globe Valve with flanged body
- 4 Type 2433 Three-way Valve with female thread/male thread
- 5 Type 2430 Control Thermostat
- 6 Type 2403 Safety Temperature Monitor (STM)
- 7 Type 2439 Safety Temperature Limiter (STL)
- 8 Type 2438 Hydraulic Controller
- 9 Electric signal transmitter (optional)

Valves with TR

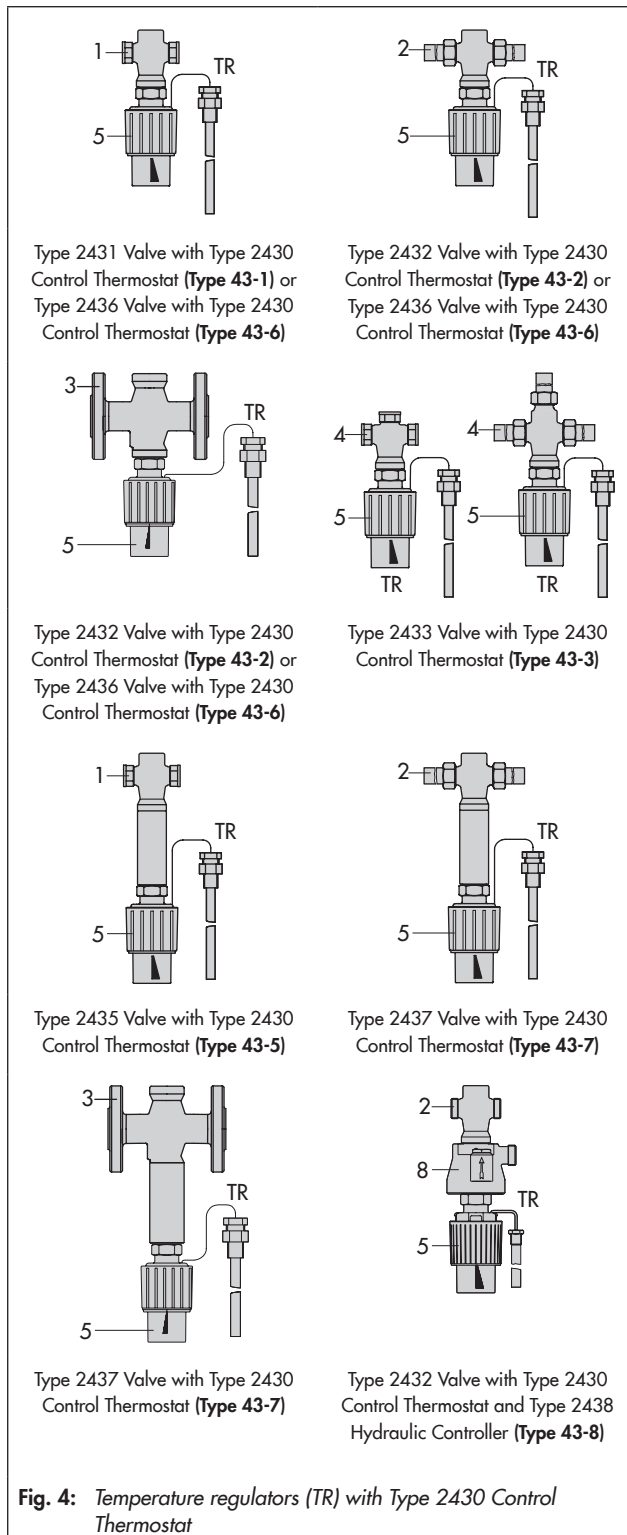

Temperature regulators (TR) · See Fig. 4

Temperature regulators (TR) consist of a Type 2430 Control Thermostat (5) and a valve (1 to 4).

They control the temperature and regulate the energy supply when the temperature exceeds the adjusted set point.

Valves with STM

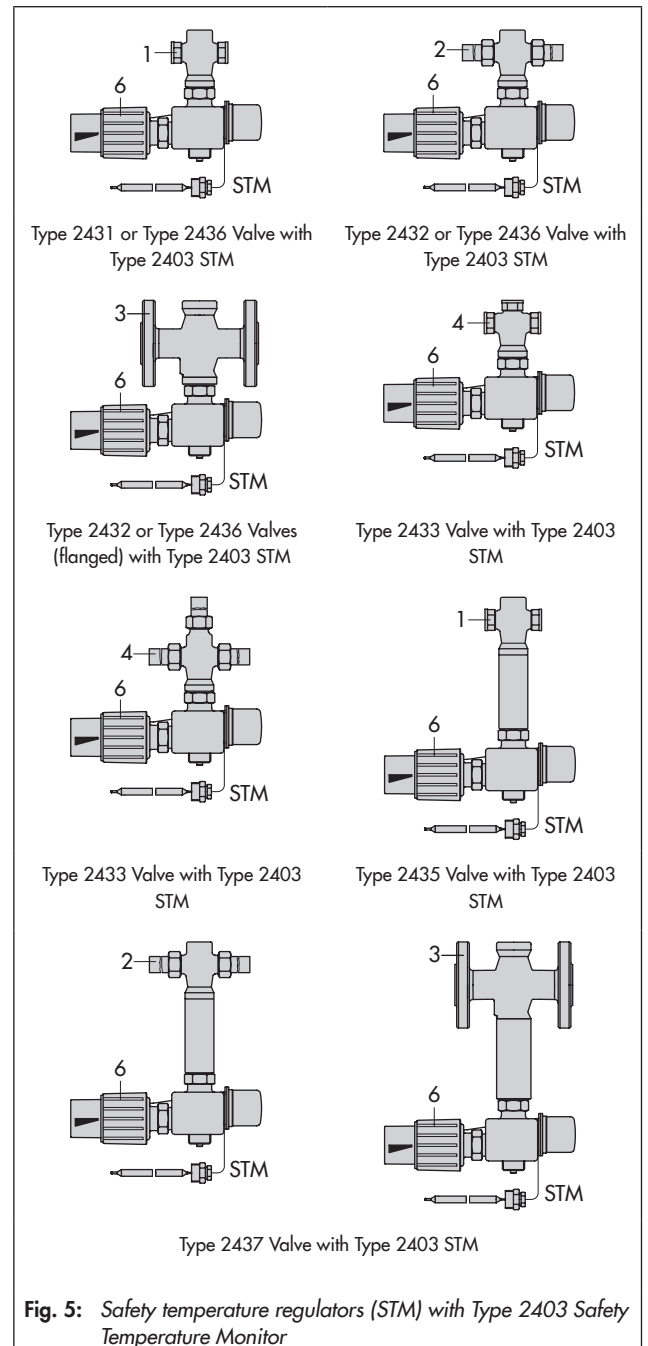

Safety temperature regulators (STM) · See Fig. 5

The safety temperature regulator (STM) consists of a Type 2403 Safety Temperature Monitor (6) and a valve (1 to 4).

The safety temperature monitor closes the valve when the temperature reaches its limit (adjustable between 60 to 75 °C, 75 to 100 °C or 100 to 120 °C) as well as when the capillary tube ruptures or when there is a leak in the sensor. It resets itself automatically when the fault has been remedied and the temperature has fallen below the limit.

Valves with TR/STM

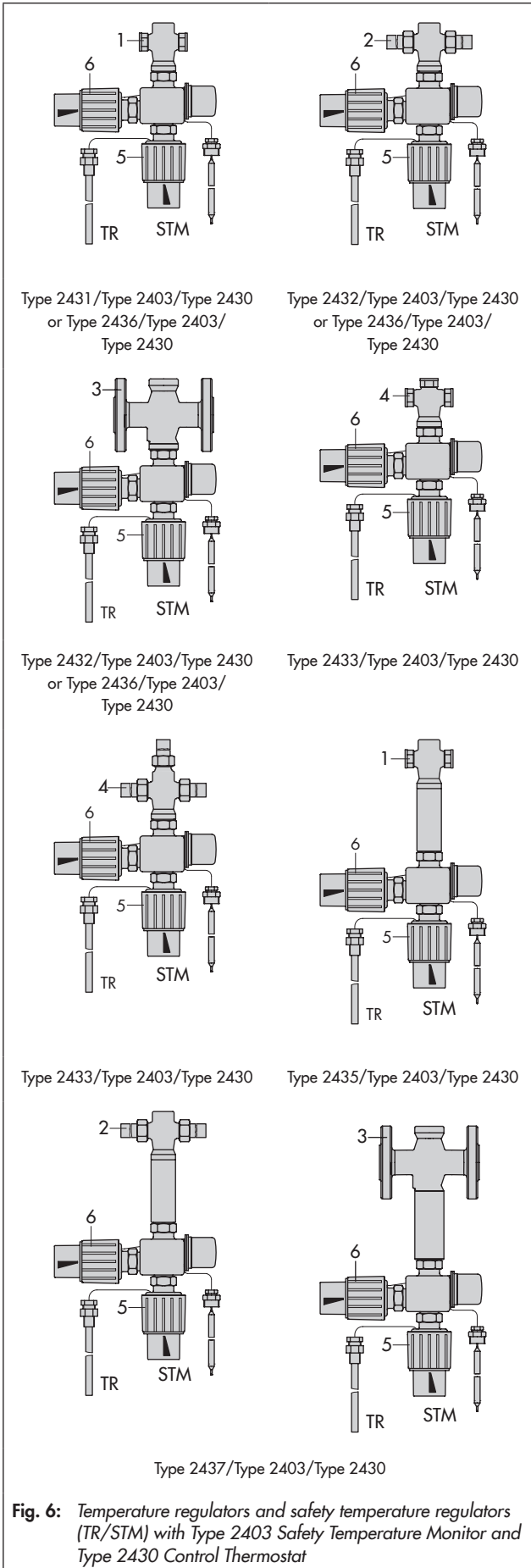

Valves with STL

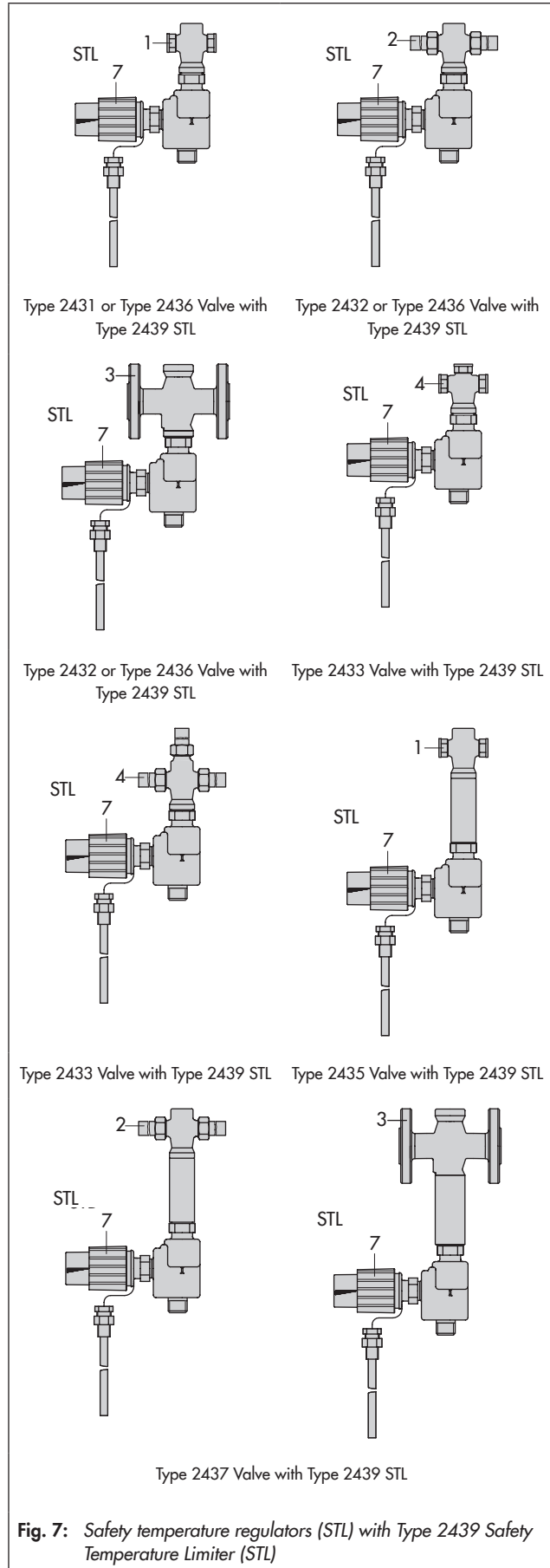

Valves with TR/STL

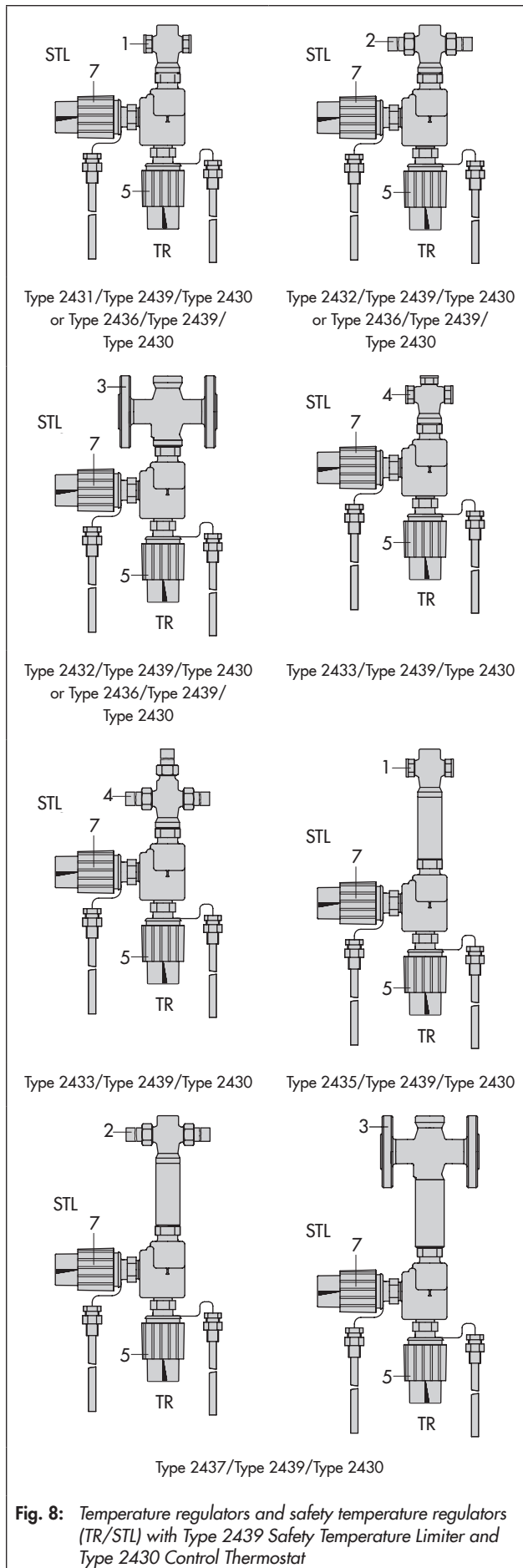

Temperature regulator and safety temperature regulator (TR/STM) · See Fig. 6

The combined TR/STM consists of a Type 2403 Safety Temperature Monitor (6) as well as a Type 2430 Control Thermostat (5) and a valve (1 to 4).

The Type 2430 Control Thermostat (5) additionally mounted at the spring mechanism of the STM acts as a temperature regulator in this case.

Safety temperature regulator (STL) · See Fig. 7

The safety temperature regulator (STL) consists of a Type 2439 Safety Temperature Limiter (7) and a valve (1 to 4).

The spring mechanism in the safety temperature limiter closes and locks the valve when the temperature reaches its limit (adjustable between 40 to 95 °C or 70 to 120 °C), when the capillary tube ruptures or when there is a leak in the sensor.

The limiters can only be unlocked and put back into operation with a screwdriver after the temperature has fallen below the limit and the fault has been remedied.

Temperature regulator and safety temperature regulator (TR/STL) · See Fig. 8

The combined TR/STL consists of a Type 2439 Safety Temperature Limiter (7) as well as a Type 2430 Control Thermostat (5) and a valve (1 to 4).

The Type 2430 Control Thermostat mounted at the Type 2439 Safety Temperature Limiter acts as a temperature regulator (TR) in this case.

Electric signal transmitter (see Fig. 9)

The Type 2439 Safety Temperature Limiter can be delivered with an electric signal transmitter for remote transmission of a malfunction.

